

Fireray Hub Reflective

**System: [EN] 6020-100
[UL/FM] 6020-300 [AS] 6020-500**

**Detector: [EN] 6030-100
[UL/FM] 6030-300 [AS] 6030-500**

The Fireray Hub Reflective system is a modular beam detection system that can be specified to suit a variety of demanding applications.

Benefits of Fireray Hub

- The Fireray Hub Reflective enables excellent accessibility and user-configurable settings for long-term ease of maintenance and ownership
- Connect up to three Fireray Reflective Detectors, on a single cable run
- FFE Reflective motorised beam technology – Auto-Alignment™, Building Movement Tracking™ and Light Cancellation Technology™

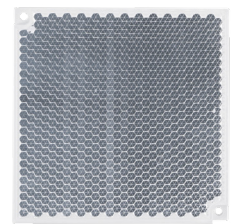

FEATURES	
Detection range:	8 to 50 m (26 to 164 ft) ¹ 50 to 120 m (164 to 394 ft) with Reflective Long Range Kit
Extent	Allows for 3 Reflective Detectors per System Controller
Alignment method	Laser-assisted, motorised Auto-Alignment™ from the System Controller. Manual alignment – optional setting
Building Movement Tracking™	Compensates for natural shifts in alignment from building movement ²
Contamination compensation	Compensates for gradual build-up of contamination on the optical surfaces
Light cancellation technology™	Compensates for high levels of sunlight and artificial lighting
Optical wavelength – smoke detection	850 nm near infrared (invisible)
Integrated laser – laser alignment	650 nm visible. Class 3R <5 mW
Dynamic beam phasing	Beam Detectors can be mounted facing each other with the Reflectors in the middle
Signal output	Individual Alarm and Fault relays (VFCO) max. 1 A @36 Vdc for each Detector

¹For UL approved installations, the minimum separation is 10 m (33ft).

²When mounted according to manufactures guidelines.

CHALLENGE	FIRERAY HUB REFLECTIVE
Large public areas Downtime for maintenance kept to a minimum	Fireray Hub Reflective allows you to monitor and test detectors without shutting down the area
Glass atria in hotels and retail complexes Sunlight can cause nuisance alarms	Light Cancellation Technology™ actively cancels sunlight to prevent nuisance alarms
Very large spaces, e.g. warehouse and aviation hangars Installation and maintenance very time-consuming	Connect up to three Detectors on a single cable run, each with 120 m (394 ft) detection range, all controlled from a single System Controller

ACCESSORIES	
1010-000	Fireray Prism (Long Range)
1150-000	Fireray Commissioning and Maintenance Kit
1170-000	Fireray Detector Adjustment Bracket
1100-000	Fireray One Protective Cage
1040-000	Fireray Prism Adjustment Bracket
1050-000	Fireray Prism Adjustment Bracket (Long Range)
1030-000	Fireray Prism Wall Bracket [White]
1070-000	Reflective Detector Anti-condensation Heater
1090-000	Fireray Prism Anti-condensation Heater [White]

APPROVALS

Worldwide approvals include EN 54-12, UL 268, FM 3230 and AS7240.12 Visit ffeuk.com for up-to-date approvals information.

SCAN THE QR CODE
TO EXPLORE THE
FIRERAY PRODUCT RANGE



Fireray Hub Reflective

Datasheet

System: [EN] 6020-100 [UL/FM] 6020-300 [AS] 6020-500

Detector: [EN] 6030-100 [UL/FM] 6030-300 [AS] 6030-500

DESIGN SPECIFICATION

Beam path clearance	0.5 m (1¾ ft) radius from centre line between Detector and Reflector
Maximum number of Detectors per System Controller	3 Reflective Fireray Detectors
System Controller dimensions	170(h) x 274(w) x 73(d) mm (6¾"(h) x 10¾"(w) x 2¾"(d))
Detector dimensions	131(h) x 134(w) x 131(d) mm (5¼"(h) x 5¼"(w) x 5¼"(d))
Reflector dimensions	Up to 50 m (164 ft) separation distance – Single Reflector 100(h) x 100(w) x 9(d) mm (4"(h) x 4"(w) x ½"(d)) Up to 120 m (394 ft) separation distance – Four Reflectors 200(h) x 200(w) x 9(d) mm (8"(h) x 8"(w) x ½"(d))
Product weight	System Controller 1.05 kg (2¼ lb) Detector – 0.57 kg (1¼ lb) Reflector – 0.06 kg (¼ lb)
Housing colours	White RAL9016, UV stable; Grey RAL7001, UV stable

ELECTRICAL SPECIFICATION

Operating voltage	14 to 36 Vdc to the System Controller
Operating current in standard alignment mode	12.5 mA with one Detector 15 mA with two Detectors 17.5 mA with three Detectors
Fast alignment mode current	33 mA (during alignment, or when LCD backlight is active)

ENVIRONMENTAL SPECIFICATION

Operating temperature	-10 to +55°C (+14 to +131°F)
Storage temperature	-40 to +85°C (-40 to +185°F)
Relative humidity	0 to 93% non condensing or icing
IP rating	Controller – IP65 Detector – IP55
Housing flammability rating	UL94 V0 polycarbonate

OPTICAL SPECIFICATION

Fault level	Signal dropping by >85% in <2 seconds
Max. angular alignment of Detector	±4.5° (±70° with adjustment bracket accessory)
Max. angular misalignment of Detector	±0.5°
Max. angular misalignment of Reflector	±5°

INSTALLATION RECOMMENDATIONS

Wiring configurations (see diagram)	Parallel mode – up to 3 Detectors individually connected to the System Controller Network mode – up to 3 Detectors connected to the System Controller on a single channel
Cable gauge and type	2-core, dedicated, 24 to 14 AWG (0.5 to 1.6 mm) (1/100" to 6/100") System compatible with fireproof and non-fireproof cable meeting local installation standards
Maximum cable length between the System Controller and Detector	100 m (328 ft) maximum to furthest Detector when in Network mode
Cable entry – System Controller	10 knock-out locations of 21 mm (¾") diameter for cable glands 10 drill-out locations of up to 21 mm (¾") diameter
Cable entry – Detector	2 knock-out locations of 21 mm (¾") diameter for cable glands 2 drill-out locations of up to 21 mm (¾") diameter

TEST AND MAINTENANCE

Alarm test	Remote detector fire test from the System Controller
Event log with time and date stamps	Time and date stamped event log with event codes providing informed diagnostics of the system – 128 per Detector, 600 per System Controller

EXAMPLE WIRING

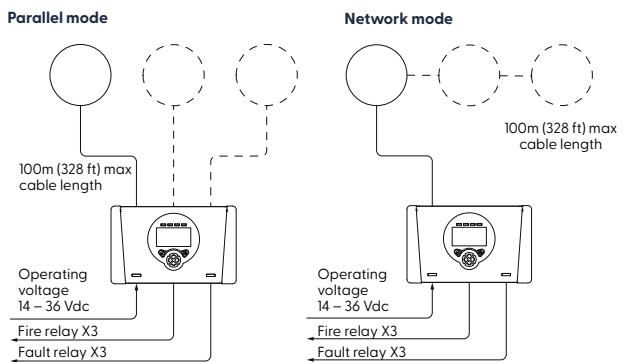

DIMENSIONS

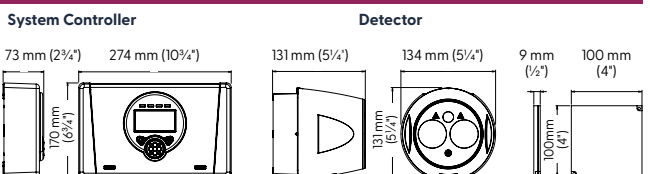

FFE Limited, 9 Hunting Gate, Hitchin, Hertfordshire SG4 0TJ, UK
t: +44 (0) 1462 444 740 w: ffeuk.com

FFE Limited, 1455 Jamike Ave Ste 200, Erlanger, KY 41018-3147, USA
t: +1 859 957 1570 w: ffeuk.com

Specifications and wiring information are provided for information only and are believed to be accurate. FFE Ltd assumes no responsibility for their use. Data and design are subject to change without notice. Installation and wiring instructions are shipped with the products and should always be used for actual installation. For more information, contact your Sales Representative. Document Part No: 24-0461-02