

3171 Ex db eb

Explosionproof Vibration Switches

The type 3171 Ex vibration switch is a low-cost, vibration-sensitive switch for the protection of rotating and reciprocating machinery in hazardous areas.

It is adjustable to operate above the machine's normal running levels of vibration, activating machine shut-down circuits and/or alarms.

Once operated the internal micro switch remains latched until reset.

The type 3171 Ex vibration switch, with its low frequency response is ideal for detection of mass imbalance on most machines. It is inherently insensitive to high frequency components and those caused by external knocks, etc. The type 3171 Ex vibration switch is responsive to vibrations in all directions.

The type 3171 Ex vibration switch is reset by depressing a button on the bottom face (see diagram below).

Adjustment of the vibration trip level is made externally at the top of the unit by rotating a sealed control.



Features

- Ease of installation on new or existing plant and machinery
- Robust for Industrial Environments
- Manual reset
- SPCO or DPCO
- Must be vertically mounted as in diagram below - sensitive in horizontal, lateral and vertical planes
- Captive lid and fasteners
- Two year warranty (from date of invoice)
- Accessories available - visit www.ffeuk.com for further details
- Blanking plug accessory for corrosion protection when mounted into the field un-wired
- Maintenance free operation

Compliance and Standards



Compliance:

ATEX Directive 94/9/EC, EMC Directive 2004/108/EC
RoHS Directive 2002/95/EC, REACH Directive 1907/2006/EC

Standards:

EN 60079-0:2013
EN 60079 parts 1, 7 and 31
GB 3836.1, 2 and 3-2010 and IEC 60079-31:2008
Safety - BS EN 60204-1:2006+A1:2009
EMC - BS EN55011 and BS EN61000-4
Salt mist - BS EN 60068-2-52:1996 test Kb severity 2

Ingress protection rating

IP66/IP67 to BS EN 60529

Applications

The 3171 is ideal for use on rotating and reciprocating machinery (below 3000rpm) such as fans, centrifuges, compressors, pumps, turbines, motors and generators, vibrating conveyors, vertical and horizontal crushers and shakers.

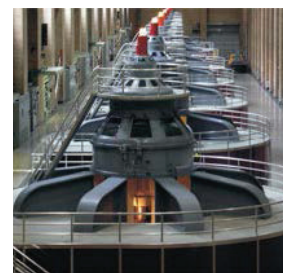

Dimensions (mm)

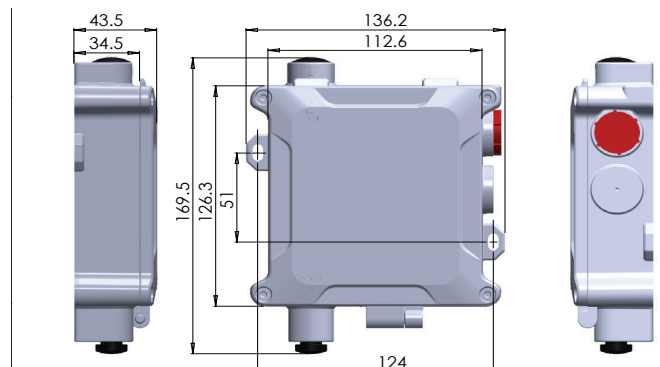

3171 Ex db eb

Vibration Switches

Specification

3171 Ex db eb Electro-mechanical vibration switch with manual reset

ATEX Classification:	II 2G Ex db eb IIC T6 Gb II 2D Ex tb IIIC T85°C Db
NEPSI Classification:	Ex de IIC T6 Gb Ex tb IIIC T85°C
Drop and free fall:	BS EN60079-0 section 26.4
Performance:	Set level range 0.5 to 9g peak acceleration
Rated operating voltage:	AC 250 V 50/60 Hz
Utilisation category:	AC-15 3A 250Vac, DC-13 0.15A 250Vdc, DC-13 3A 30Vdc
Switch rating:	Ohmic/resistive load - AC 5 A 250 V, DC 5 A 30 V Inductive/motor load - AC 3 A 250 V, DC 3 A 30 V
Enclosure material:	Die-cast zinc alloy Mazak III
Enclosure finish:	Iron passivation with goose grey polyester powder coat
Temperature range:	-50°C to +80°C
Weight:	1.5kg typical
Connections:	Internal terminal block via M20x1.5mm threaded cable entry
Mounting:	Mount vertically with reset button at bottom using fixings size M5 and anti-vibration washers or similar.
Contact Arrangements:	SPCO or DPCO
Alternative switch contacts:	Gold-plated contacts for low energy switching and/or monitoring. DC or Peak AC Ratings: Voltage: 5 V to 30 V, Current: 4 mA to 400 mA Max VA = 0.12 (Current × Voltage)

Options

Second cable entry:	The unit can be supplied with a second M20x1.5mm threaded cable entry
Pre-sets:	Where the rotating machine has a dominant frequency at 25Hz, FFE Ltd. can provide a pre-set switch between 1g & 9g

* Refer to Installation and Operating Manual

Order Code

(For example: 8101-000)

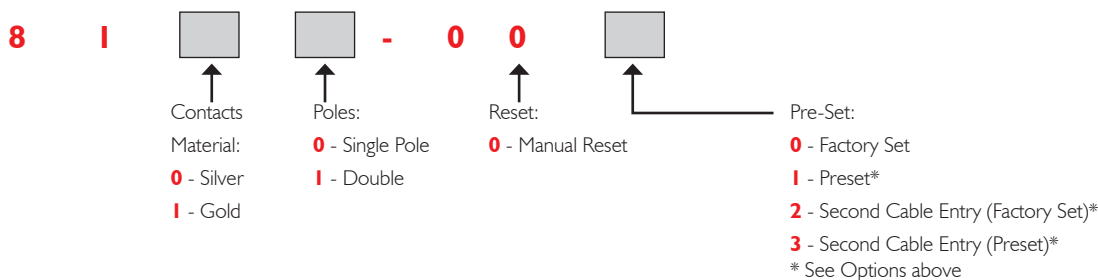

FFE Limited
9 Hunting Gate, Hitchin
Hertfordshire, SG4 0TJ UK

T +44 (0) 1462 444 740
E sales@ffeuk.com
W www.ffeuk.com

Electrical Arrangements

Double-Throw (Change-Over):

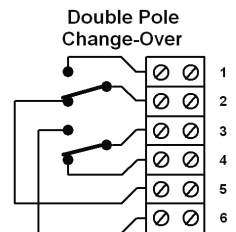
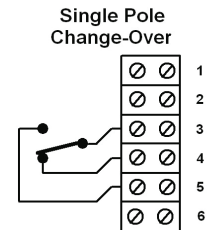

Switches are shown in their normal system operating position after a manual or remote reset has been performed

Specifications and wiring information are provided for information only and are believed to be accurate. FFE Ltd. assumes no responsibility for their use. Data and design are subject to change without notice. Installation and wiring instructions are shipped with the products and should always be used for actual installation. For more information, contact your Sales Representative.

Document Part No: 24-0047-04

www.ffeuk.com